

Measurement of Turbulent of Gas-liquid Two-phase Flow in a Bubble Column With a Laser Velocitymeter¹

SUN Qi² WANG Shuli³

Abstract: Turbulent bubbly air/water two-phase up and down flows in bubble column were investigated. Important flow quantities such as local void fraction, liquid velocity and the turbulence intensity were measured using both LDV and PIV. the presence of the bubbles increased the level of turbulence in the flow. Measurements of liquid velocities in bubble columns, of different superficial gas velocities, and of different height, the flow structures show tours vortices and axisymmetric flow.

Key words: turbulent flow; gas-liquid flow; laser velocitymeter

1. INTRODUCTION

Bubble columns find applications as gas-liquid contractors in a variety of chemical processes. One of the most important and yet least understood aspects of bubbly two-phase flow are the lateral phase distribution and turbulence structure mechanisms which occur. This multidimensional effect is often quite pronounced and must be considered in the accurate analysis of heat, mass and momentum transfer for chemical and power industry application. Much of the analysis which has been published to date has been concerned with a constant gas hole rather than variable gas distributor effects. However, the lack of information on effect of the various gas flow rate can result in significant restrictions in many practical applications. This explains the need for reliable data to permit scale-up of a bubble column reactor .

Previous experimental studies have shown that pronounced lateral phase distribution may occur. Serizawa et al. (1975) and Michiyoshi et al. (1986) .

have measured pronounced wall peaking of the local void fraction for turbulent bubbly air/water two-phase upflow in a pipe. Similar results were found by Valukina et al. (1979) for laminar bubbly air/water two-phase upflow in a pipe. These results were later confirmed in a study by Wang et al. (1987) , and were extended to show that , in contrast to the bubbly upflow results , void concentration near the pipe's centerline occurred for turbulent bubbly two-phase air/water downflow in a pipe. Fan (1989) identified that there were three different flow regimes, namely, dispersed bubble, coalesced bubble, and slugging for bubble or slurry bubble column systems. A gross circulation flow pattern is

¹ Project supported by the Jangsu Science Foundation of China. NO: BS2005020

² Jiangsu Polytechnic University, Jiangsu Key Laboratory of Oil & Gas Storage and Transportation Technology, China. E-mail: sunqi1202@126.com

³ Jiangsu Polytechnic University, Jiangsu Key Laboratory of Oil & Gas Storage and Transportation Technology, China. E-Mail: wsl@jpu.edu.cn

* Received 21 September 2008; accepted 24 November 2008

observed for these systems under both dispersed bubble and coalesced bubble regimes (Latif and Richardson, 1972; Lin et al., 1985). Generally, the gross circulation flow field comprises an upward flow in the column core and a downward stream along the wall with the inversion point (zero liquid velocity) located at about 0.5 to 0.7 radius of the column (Walter and blanch, 1983).

The purpose of the study presented herein was threefold. The first purpose was to develop reliable methods to measure such two-phase flow parameters as liquid phase velocity, turbulence intensities and local void fraction. The second purpose was to compare the measured flow parameters as the superficial gas velocities are modified with up-flow and down-flow. The third purpose was to permit the essential data for modeling gas-liquid two phase flow.

2. EXPERIMENTAL SET-UP AND METHODS

The results presented in this work were obtained in a bubble column having a constant inner diameter of 0.2 m and a height of 2.0 m. The test section was made of Pyrex glass and enclosed in a rectangular box made of glass. The column was aerated at the bottom using a sieve plate with the hole diameter of 0.2 mm, holes uniformly spaced and the number of hole modified from one to twenty-one. The superficial gas velocity was 0.0 cm/s、0.18 cm/s、1.429 cm/s、4.25 cm/s. The superficial liquid velocities ranged at 2.0 cm/s、2.5 cm/s、3.0 cm/s. At the height of $h=0.5$ m、 $h=0.7$ m and $h=0.9$ m, the two-phase flow parameters were measured with a Laser Doppler Anemometer (LDV) and a particle image velocimetry (PIV) system. The laser sheeting technique is used for flow visualization. A 4.5 W argon ion laser system is used as the laser source. A high resolution (800×490 pixel) CCD camera is utilized to record the image of the flow field. The set-up is schematically in Fig.1.

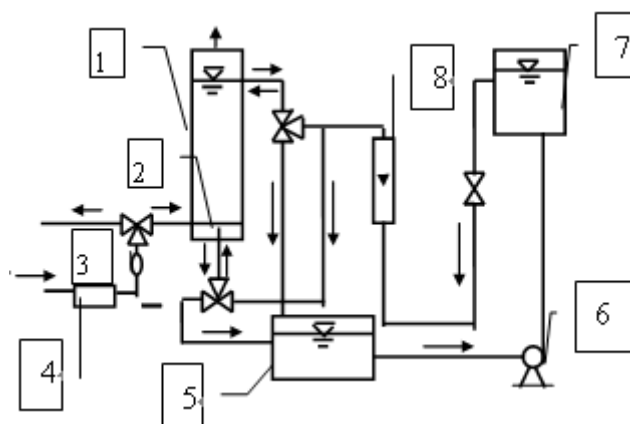

1 Bubble Column; 2 Bubble Injector; 3 Flowmeter(1#); 4 Air Compressor; 5 Bottom Water Tank; 6 Pump; 7 Top Water Tank; 8 Flowmeter (2#)

Fig.1 Schematic of the experimental facility

This PIV technique consists of laser sheeting, video recording, and image processing as the three major parts. Besides the ability of measuring the full-field flow information including velocity vectors, holdups, and accelerations, this PIV system is able to discriminate the flow properties among different phase which renders it unique and suitable for three-phase fluidization measurement.

3. THE RESULT AND DISCUSSED

3.1 Mean Liquid Velocities

Fig.2 shows the radial profiles of the mean axial liquid velocity when the gas velocity equal to zero. Fig.3 and Fig.4 shows the mean axial liquid velocity upward/downward flow at the locations of $h=0.5$ m and $h=0.9$ m from the gas distributor. The following characteristics of the presented velocity profiles should be emphasized:

1st. The maximum upward/downward liquid velocities on the axis of the approximately parabolic radial profiles increase with instance from the gas distributor. they reach a maximum value in the top of the column.

2nd. All operating conditions lead to similar profiles of heightdependent.

They confirm the existence of a stable axially asymmetric flow structure in the bubble column. An important parameter affecting the flow behavior is the superficial gas velocity. Fig.3 and Fig.4 show the influence of increasing superficial gas velocity in the range 2.0 cm/s to 3.0 cm/s. The profiles become steeper with increasing gas velocity. However, further increases in superficial velocity of up to 7.0 cm/s do not alter the liquid velocity profiles to any significant extent. the location of the maximum liquid velocity occurred at the pipe's centerline. Reversals of flow were presented near the wall. The location where velocities are zero is a function of U_L/U_G .

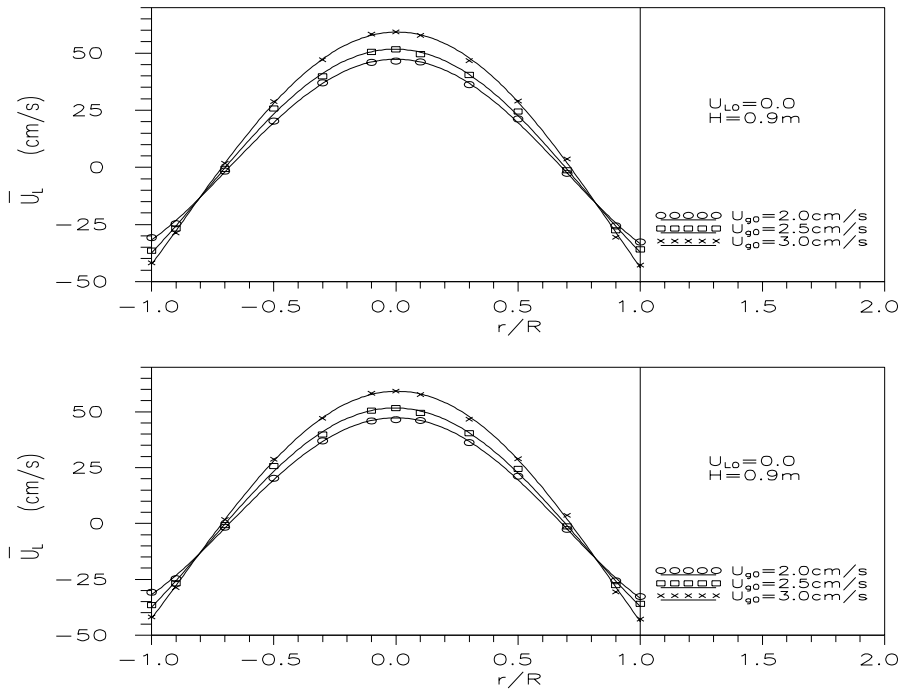

Fig. 2 Liquid velocity distribution

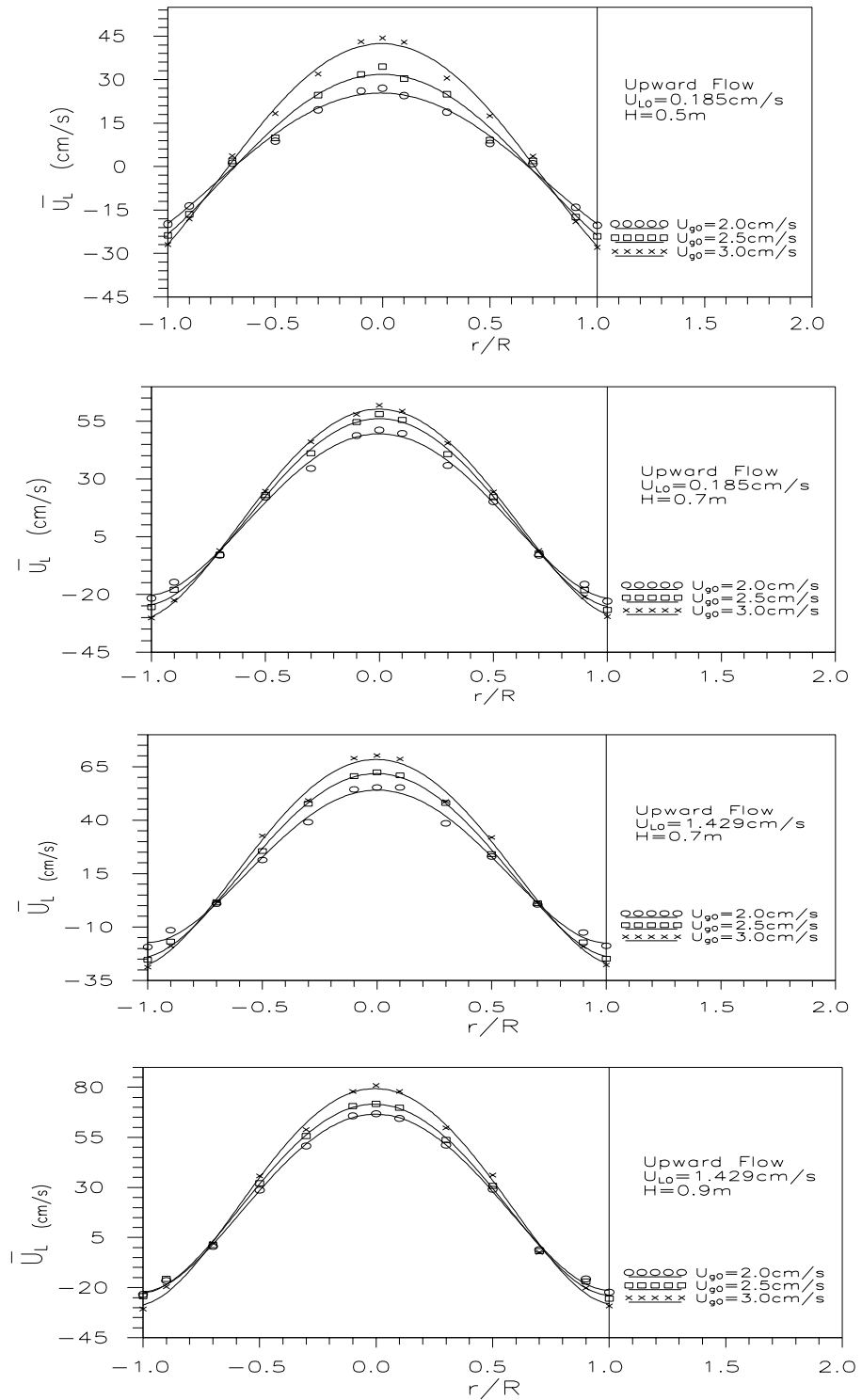

Fig.3 Profiles of axial mean velocity, upward flow

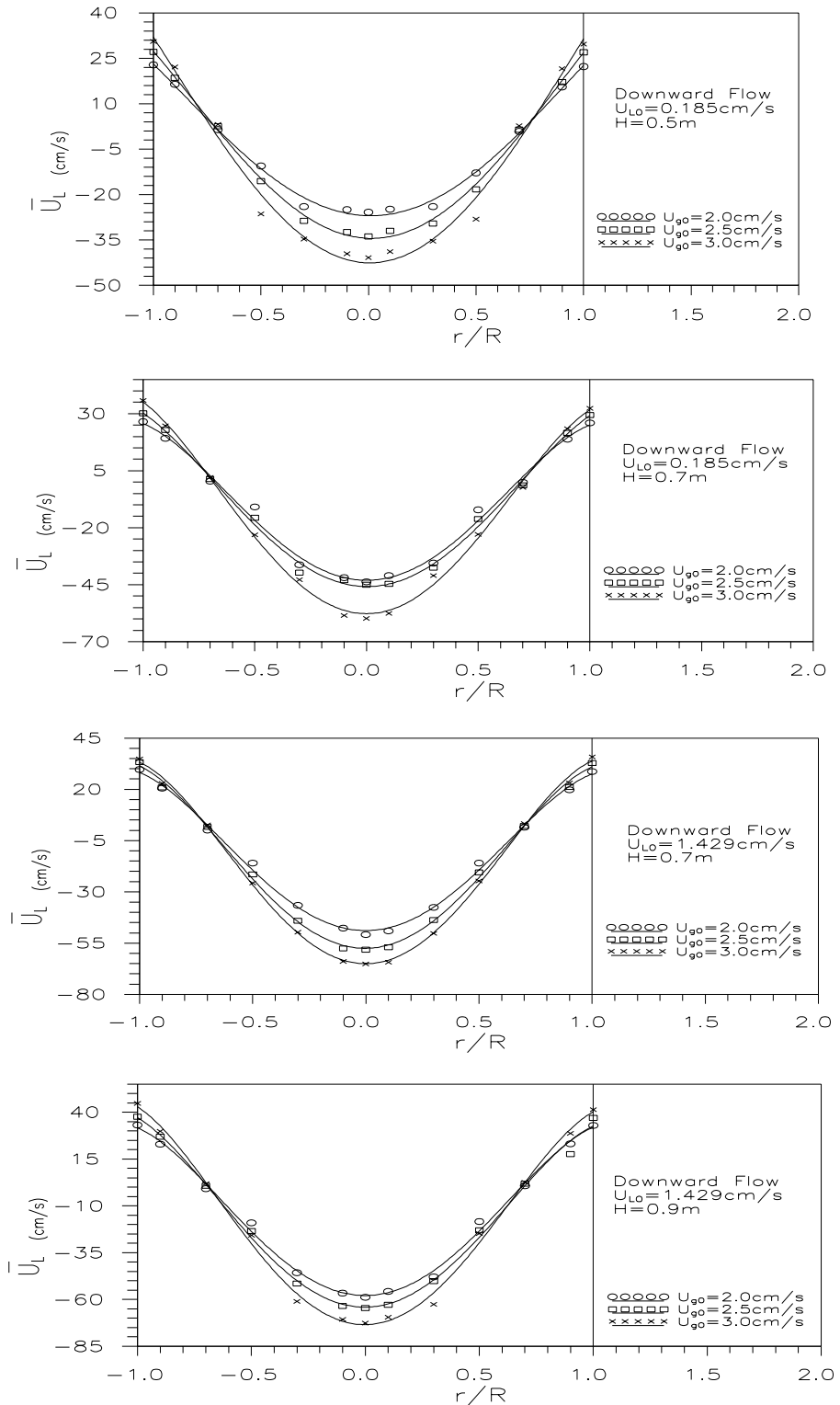

Fig. 4 Profiles of axial mean velocity, downward flow

3.2 Turbulence intensities

Fig.5 presents turbulence intensities $u'(r)$ for the range of u_{g0} from 2.0 cm/s to 3.0 cm/s. In comparison to the values known from single-phase flow, the intensities are exceptionally high and increase still further with increasing superficial gas velocities whereas the liquid velocity along the axis increases. the location of maximum turbulence intensities occurs at about $r/R=0.7$ where is a zone with a high velocity gradient.

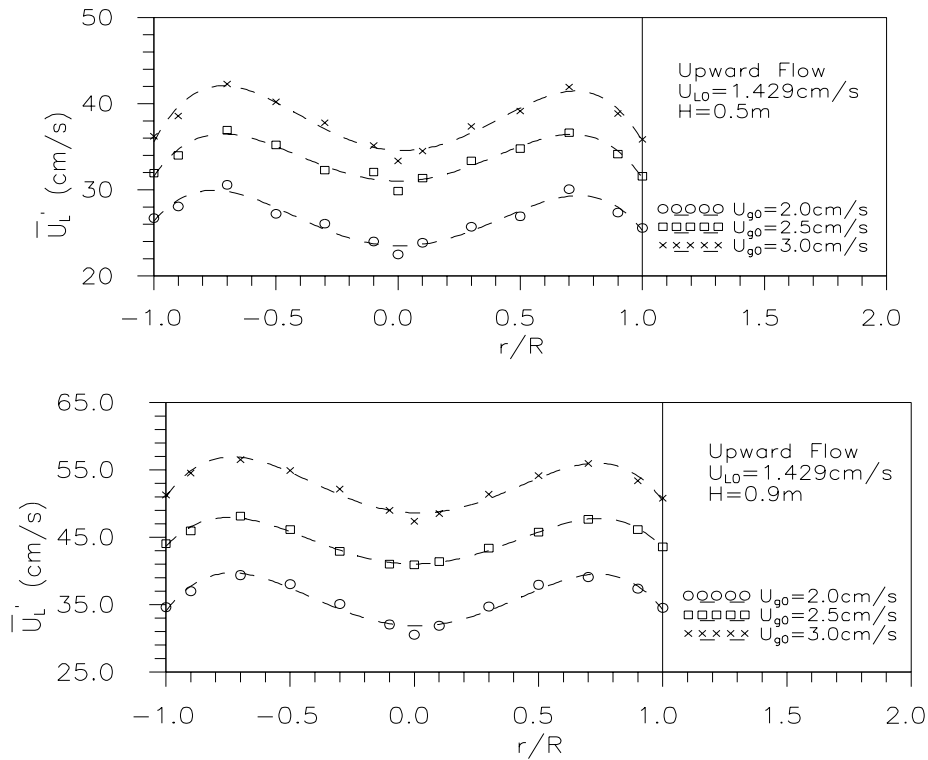
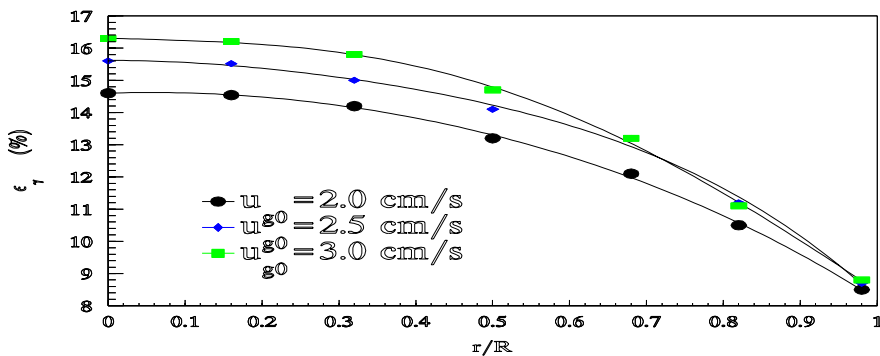

Fig. 5 Radial profiles of turbulence intensities in axial direction, upward flow

3.3 Void fraction

The void fraction data were measured with particle image velocimetry (PIV) system. Fig.6 and Fig.7 shows the profiles of void fraction upward flow and downward flow.



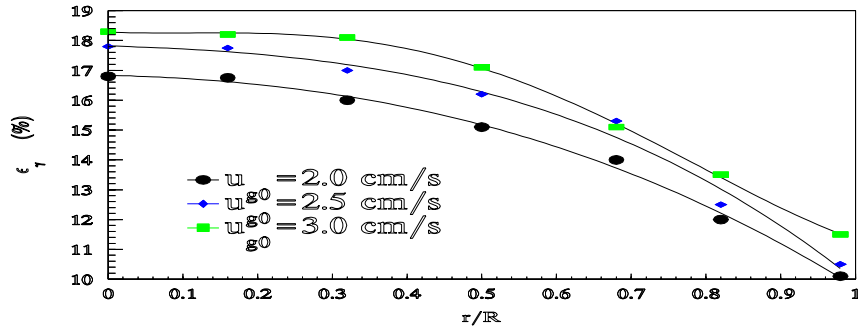

Fig. 6 Void fraction profiles, Upward flow

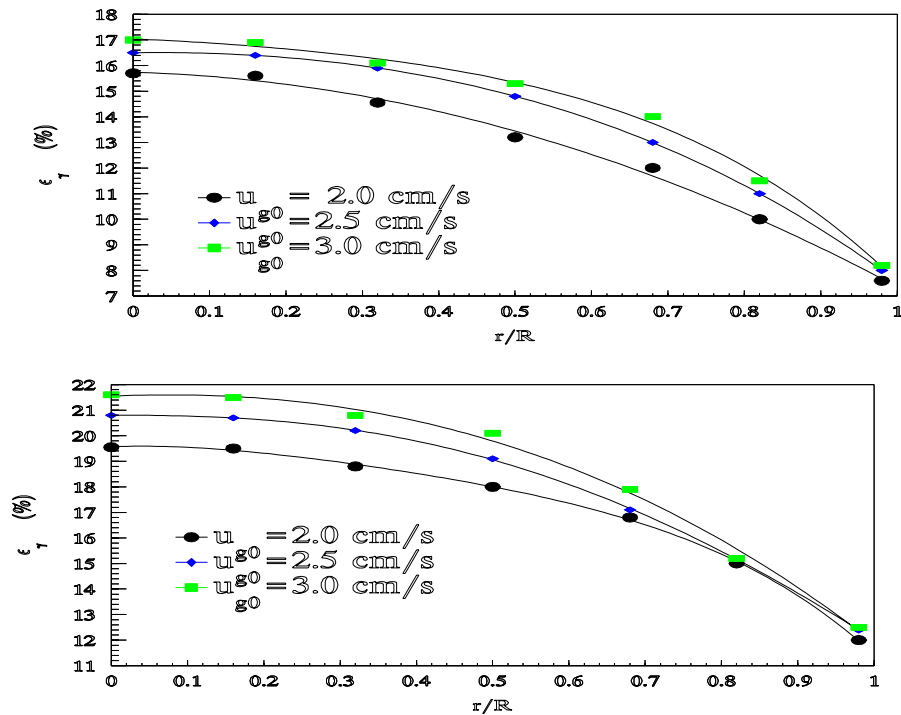

Fig. 7 Void fraction profiles, Downward flow

It was found that the bubbles tended to Margaret toward the center of the bubble column. Void fraction distributions were parabola, and the peak near the axial. At the same height of the bubble column, and the same superficial liquid velocity, the void fraction was increased as the superficial gas velocity was increased. At the same operation condition, the void fraction was increased as the height of the column become higher.

4. SUMMARY AND CONCLUSION

In order to better understand phase distribution mechanisms, both LDV and PIV anemometer were used to measure the void distribution, mean velocity and turbulence structure of the continuos.

In general, the liquid velocity profile was parabola. The peaking was near the center of the column. The gas phase also redistributes the radial variation of turbulent fluctuations. In the core region, the normal turbulent fluctuations and void fraction frequently showed that flat profiles. Interestingly, these fluctuations increase monotonically as the void fraction increases. The presence of bubbles in turbulent flows enhances dissipation of turbulent kinetic energy as well as promoting its production

REFERENCES

- Serizawa. A., Kataoka and Michiyoshi, Turbulence Structure of Air-Water Bubbly Flow. Transport Properties, *Int. J. Multiphase Flow* 2(1975), 247-259.
- Michiyoshi I & Serizawa A., Two-Phase Flow Studies in Japan, *Int. J. Multiphase Flow* 15(1986), 679-733.
- Valukina. N. V. and B. k. K. Kozmenko, Characteristics of a flow of Monodisperse Gas-Liquid Mixture in a Vertical tube, *Inzhenerno-Richenskii Zhurnal*, 36(1979), 695-699.
- Wang. S. K and Lee. S. J, 3-D Turbulence Structure and Phase Distribution Measurements in Bubbly Two-Phase Flow. *Int. J. Multiphase Flow* 15(1987), 327-345.
- Fan. L. S., *Gas-liquid-solid fluidization engineering*, Butterworth, stoneham, MA(1989).
- Latif. B. A. J., and Richardson. J. F, Circulation Patterns and Velocity Distributions for Particles in a Liquid Fluidized Bed, *Chem. Eng. Sci.*, 27(1972), 1933.
- Lin. J. S., and Chen. M. M., A Novel Radioactive Particle Tracking Facility for Measurement of Solids Motion in Gas Fluidized Bed, *AIChE J.*, 31(1985), 465.
- Walter. J. F. and H. W. Blanch, Liquid Circulation Patterns and Their Effect on Gas Hold-Up and Axial Mixing in Bubble Columns, *Chem. Eng. Commun.*, 19(1983), 243.
- Chen, R. C. and Fan, L. S., Particle Image Velocimetry for Characterizing the Flow Structure in Two-Dimensional Gas-Liquid-Solid Fluidized Beds. *Chem. Engng. sci.* 47 (1992) , 3615-3622.